

10.0 APPROVAL REQUIREMENTS

This section applies to tag designs that are approved for use in interchange service. Equipment owners may choose to use other tags in addition to those required by the interchange rules for supplementary applications.

10.1 Approval of Tags

All new tag designs and changes to existing tag designs that are approved for use in interchange service must be approved by the Equipment Engineering Committee, Mechanical Division. Each tag design shall be identified by type. The approval shall remain in effect as long as no changes are made in the tags or in the specification requirements.

10.2 Facility Certification

As a minimum, all tags must be manufactured in a facility certified as meeting or exceeding AAR Quality Assurance Specification M-1003.

10.3 Design or Manufacturing Changes

10.3.1 Changes to Tags

If a manufacturer desires to make any changes in an AAR-approved tag, the manufacturer shall advise the Director—Freight Car Construction and Components, providing full information as to the nature of the proposed change and the reason for the change. If a new issue of a drawing or specification is made for the purpose of clarifying or correcting it, notice shall also be provided. The Equipment Engineering Committee will decide in each case what action is to be taken on these changes and, in the event they are approved, the appropriate documentation describing the change (e.g., drawing(s) and specification) will be included with the approval record.

10.3.2 Changes to Specification

If changes are made in the specification, the Equipment Engineering Committee will take the necessary action to determine whether approved tags conform to the changed specification.

10.3.3 Certification of Approval

A manufacturer shall furnish to each purchaser of tags covered by AAR approval a guarantee that the tags furnished are the same as those covered by the approval.

10.3.4 Configuration Control Procedure

Configuration of tags shall be controlled in accordance with Military Standard 481, latest revision.

10.4 Tag Reconditioning Requirements

This section applies to tags that have the programming port plug removed for any reason.

10.4.1 Facility Certification

As a minimum, all tags must be reconditioned in a facility certified to AAR Quality Assurance Specification M-1003.

10.4.2 Tag Inspection

Each tag shall be inspected. The tag shall be scrapped for the following defects:

- Physical damage to the tag, including deformity, dent, scrape, or gouge in the tag case.
- Cracks anywhere on the tag case.
- Deformity of the tag plug hole, including oval shape or scoring.
- Any indication of the presence of water in the tag (e.g. condensation or white residue).
- Tag more than 5 years old measured from the date of manufacture on the face of the tag (year is the second two digits from the left; see paragraph 2.2.1.4).

10.4.3 Leak Test

Each tag shall be leak tested. The leakage shall not result in a pressure drop exceeding .25 psig in 15 seconds when the tag is pressurized to 5.0 psig. Measurement accuracy shall be ± 0.1 psig.

10.4.4 Radio Frequency Functional Test

The tag shall respond properly when subjected to an RF field of 3.5 V/m.

A typical RF functional test fixture is described below:

- Using off-the-shelf components from Amtech, this RF test station can be constructed and incorporated into a tag programming workstation. The components include the following:
- Amtech AI1200 reader
- Amtech AR2200 RF unit
- RF attenuator (around 18dB)
- Amtech AA3140 log periodic antenna
- Wooden support (similar to drawing)

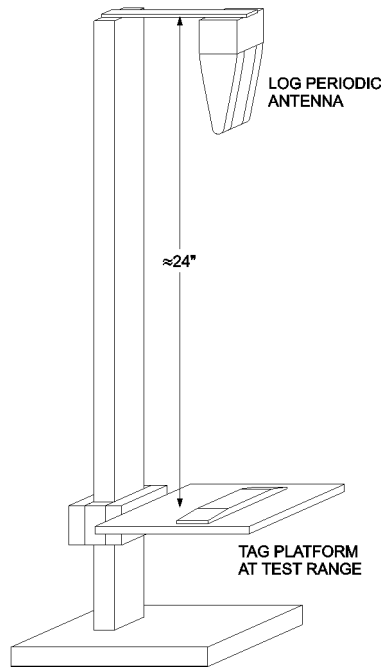

Fig. 10.1 Tag platform at test range

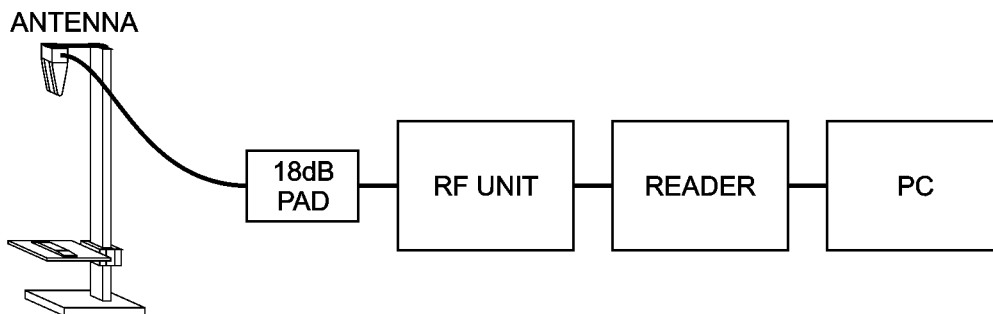

Fig. 10.2 Tag platform with typical electronic configuration